

KOMATSU®

GD663A-2

HORSEPOWER116 kW 155 HP @ 2200 min⁻¹134 kW 180 HP @ 2200 min⁻¹**OPERATING WEIGHT**

13350 kg

BLADE LENGTH

3.71 m

**GD
663A****MOTOR GRADER**

Photos may include optional equipment.

HIGH RELIABILITY

High strength main frame and tough power train make it easy to complete heavy-duty jobs.

Main Frame

The main frame is a flanged box section structure. Side plates have been added to increase strength and thereby improve durability. This durable structure guards against bending and twisting forces generated by the load on the blade.

Engine

The job-proven KOMATSU 6D125 and S6D125 diesel engine deliver a healthy 116kW (155HP) and 134kW (180HP) - more than enough for the most rugged tasks. The torque increases by 30% in the 155HP engine, and by 13% in the 180HP engine to give the machines unrivaled performance in heavy duty work.

Transmission

The HYDROSHIFT transmission is controlled by a single lever for ease of use, and is designed to minimize engine power loss. The High-Low clutch has been moved to the upper part of the transmission. Therefore, transmitting efficiency has been increased while preventing the transmission from overheating. With the installation of a reduction gear in the transmission input shaft, the revolutions of each transmission clutch is reduced.

Final Drive

The final reduction gear has a simple structure - a one-stage reduction of the spiral bevel gear.

Tandem Drive

The power transmitting between the rear axle and wheel shafts is a roller-chain-drive-type. Roller chains are double strand to obtain a large reduction ratio. The wheel shaft and wheel hub are of a monolithic structure. Thus the GD663A series has high reliability.

Parking Brake

The parking brake is installed on the transfer shaft in a positioned higher than on conventional machines, thereby preventing mud, soil, and water from contaminating it.

Axles

- Front Axle
 - The front axle is a Reverse-Elliot type, in which the wheel shaft revolves.
 - The axle diameter is enlarged to increase durability.
 - The pitman arm is higher off the ground than on conventional types, which facilitates travel over rocks or other obstacles.
- Rear Axle
 - The full-floating type axle is superior in durability because bending moment does not affect the drive shaft.



Reliable and efficient hydraulic system provides powerful and fine blade control.

The hydraulic circuits for the work equipment employ a highly reliable one-pump with a flow-divider system that reduces mechanical friction loss. The circular revolution speed is 11 degrees per second and fine control is easy. Pilot check valves are provided on blade lift, tire leaning, and articulation and drawbar side shift circuit mechanisms, thus preventing the GD663A from hydraulic drift. The GD663A provides high accuracy surface finishing - a vital role of the motor grader.

HIGH PRODUCTIVITY

Ideal weight distribution enables the blading of harder ground with excellent machine stability.

The blade load on the GD663A is superior for grading and trenching in hard soil. The load ratio on the front wheel is at approximately 30% - an ideal value for superior grader operations for eliminating the side-slip of the front wheel. Therefore, turning and digging operations can be performed with outstanding stability.



Wide blade range and frame articulation make this machine ready for versatile operations.

Because it provides a large shoulder reach, blade lift height, and digging depth, the GD663A facilitates various kinds of work. Bank cut pin control can be carried out easily from the operator's compartment. By increasing the shoulder-reach (blade overhang from rear wheels an additional 815 mm) by using articulation, the shoulder of a road can be finished without traveling on the shoulder. With a minimum turning radius of 7.1 m, the machine exhibits its unrivaled maneuverability.



ENHANCED OPERATOR COMFORT

Operator's compartment is mounted on rear frame, giving the driver excellent visibility and easy operation.

The operator faces the machine's direction of travel even during offset operation. Therefore, perception is always at an optimum angle. When the machine is articulated, the operator steers with similar feeling of an automobile because the operator's compartment is mounted on the rear frame. On the GD663A, articulation does not hamper the visibility. The compact engine compartment provides excellent rear visibility. Moreover, the optional cab with wide range of glass ensures excellent visibility.



SPECIFICATIONS



ENGINE

ModelKomatsu 6D125
 Type 4-cycle, water-cooled, overhead-valve, diesel engine
 Aspiration Natural aspiration
 No. of cylinders6
 Bore x Stroke 125 mm x 150 mm
 Piston Displacement11.05 L
 Flywheel Horsepower .. 116 kW 155 HP @ 2200 min⁻¹ (SAE J1349)
 Governor All-speed, mechanical
 Electrical starting motor24 V/7.5 kW
 Alternator.....24 V/35 A

Model Komatsu S6D125
 Type 4-cycle, water-cooled, overhead-valve, diesel engine
 AspirationTurbocharged
 No. of cylinders6
 Bore x Stroke 125 mm x 150 mm
 Piston Displacement11.05 L
 Flywheel Horsepower .. 134 kW 180 HP @ 2200 min⁻¹ (SAE J1349)
 Governor All-speed, mechanical
 Electrical starting motor24 V/7.5 kW
 Alternator.....24 V/35 A



HYDROSHIFT TRANSMISSION

The Komatsu HYDROSHIFT transmission consists of planetary gears and hydraulically actuated and force-lubricated multiple-disc clutches, assuring light-touch, effort-minimizing shifting. Both speed shifting and direction changes are completed by a single lever. With the inching pedal, precise finishing operation and smooth machine starts are ensured. A super wide range of 6 forward and 6 reverse speeds match all job requirements. Accidental machine starts are prevented by a gearshift lock device. The engine starts only when the shift lever is set in the neutral position.

Travel speeds (at rated engine speed)

	1st	2nd	3rd	4th	5th	6th
Forward	3.7	6.6	11.3	15.5	27.6	47.2
Reverse						
km/h	4.5	8.1	13.8	18.9	33.6	57.6
Max. drawbar pull	7550 kg					



FINAL DRIVE

Final Drive: Spiral bevel gear, single reduction, no-spin differential is optionally available.

Tandems: Roller-chains are double strand for obtaining a large reduction ratio. Tandem case swings up to 13°, assuring high machine stability and positive traction during operation.

Dimensions of Tandem

Height x width 580 mm x 221 mm
 Sidewall thickness, Inner/outer 22 mm/19 mm
 Wheel axle spacing1535 mm
 Drive chain pitch (double strand type)..... 31.75 mm
 Ground clearance.....320 mm



AXLES

Front axle: Reverse Elliot-type front axle with a center ground clearance of 630 mm and oscillation angle of 32°(total) assures stable machine travel. Hydraulic front wheel leaning (20°to each side).

Rear axle: Full-floating rear axle is made of forged heat-treated steel.



WHEELS

Front and rear tires 14.00-24-10PR (G-2) traction-type tubed tires
 Rims9.00 TG x 24 (SDC)
 Inflation pressure.....2.45 kg/cm² (240 kPa)



STEERING

Full-hydraulic orbital valve type steering control system with two or one steering cylinders are directly actuated on the knuckle arm. Maximum steering angle of front wheels is 49° to left and right. Frame articulation angle26°, left and right
 Min. turning radius (frame articulated) 7.1 m



BRAKES

Service brakes: Foot-operated hydraulically actuated internal expanding type on 4 rear wheels. Hydraulic booster for sure braking.
Parking brake: Mechanical internal expanding type actuated on transmission shaft.



FRAMES

Frames are articulated by two hydraulic cylinders. Box-sectioned front frame is steel-plate-welded constructed and connected with an articulation pin. One-piece-frame design for the front frame on which hydraulic pipings are installed offers excellent front visibility for more precise operations.

Front Frame

Section (width height) 280 mm x 300 mm
 Plates thickness (top and bottom, side) 25 mm, 14 mm
 Linear weights maximum, minimum 228 kg/m, 165 kg/m
 Section modules minimum2013 cm³

Rear Frame: Solid and steady frame which is constructed with square bars.



BLADE EQUIPMENT

Drawbar: A shaped, U-section press-formed and welded structure for maximum strength.

Circle: Hydraulically controlled, internal gear type circle with 4 guide shoes for smooth 360°rotation.

Circle diameter (outer)1350 mm / 1410 mm
 No. of teeth 58 / 64

Moldboard: Box-section constructed with wear-resistant steel. Hydraulic blade side shift and manual tip control. Reversible side edges and overlay end bits are attached.

Length x height x thickness3710 mm x 645 mm x 19 mm
 Blade base 2600 mm
 Blade load 6490 kg

Cutting edges: Curved type cutting edges meet SAE standard J739b.

No. of cutting edges2
 Length x height x thickness1829 mm x 152 mm x 16 mm
 Bolt diameter..... 16 mm



BLADE RANGE

All blade movements and positionings can be hydraulically controlled from the operator's seat.

Max. lift above ground450 mm
 Max. drop below ground535 mm
 Circle center shift (Left/Right)785 mm /925 mm
 Moldboard sideshift (Left/Right)815 mm /815 mm
 Max. shoulder reach:

Left2000 mm
 Right2000 mm

Max. bank cutting angle..... 90°
 Cutting angle 29° to 77°



HYDRAULIC CONTROL UNIT

Hydraulic pumps:

Tandem gear pump for work equipment and steering control
 Capacity82 L + 41 L /min
 One gear pump for HYDROSHIFT transmission
 Capacity93 L /min

Hydraulic motor: Orbitroll type hydraulic motor of 28.6 HP (21.3 kW) output power is used for blade rotation.

Hydraulic cylinders: Double-acting piston type hydraulic cylinders: two for blade lifting, one for drawbar sideshifting, one for blade sideshifting, one for front wheel leaning, two for front wheel steering and two for frame articulation. Pilot check valves assure positive cylinder action (excluding a blade sideshift cylinder).

3-spool and 4-spool type control valves for work equipment controls. Relief valve installed on control valves for sure control.

Relief valve setting:

Work equipment..... 200 kg/cm²
 Steering 175 kg/cm²
 Transmission 30 kg/cm²



SERVICE REFILL CAPACITIES

Coolant 50 L
 Fuel tank 285 L
 Engine 30 L
 Transmission 35 L
 Tandem case (total) 70 L
 Final drive case 16 L
 Hydraulic oil 30 L
 (Hydraulic tank capacity) 82 L
 Circle drive housing 4 L



OPERATING WEIGHT (APPROXIMATE)

Operating weight, including rated capacity of lubricant, coolant, full fuel tank, hydraulic equipment, operator, 3710 mm blade, 14.00-24-10PR (G-2), traction-type tires, and the standard equipment.

On front wheels3915 kg
 On rear wheels9435 kg
 Total weight13350 kg

DIMENSIONS

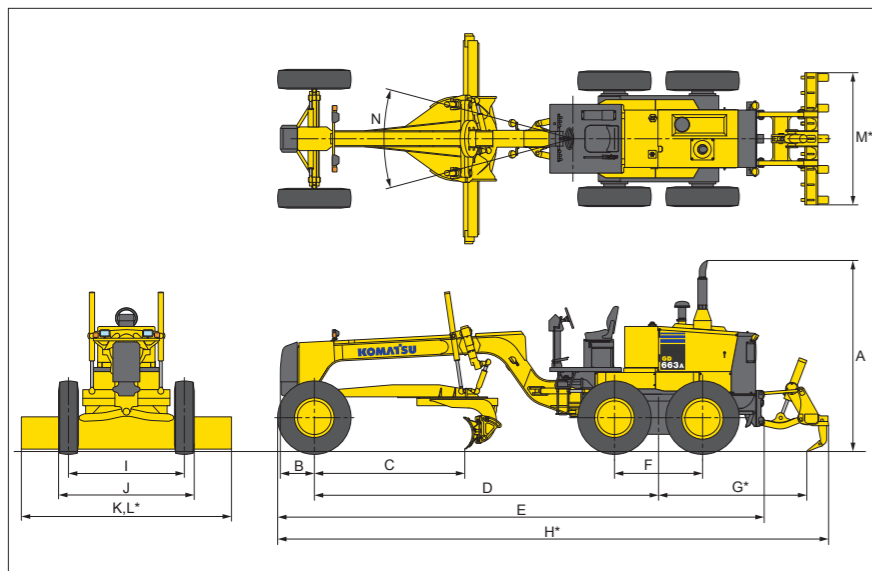

A	Height	3065 / 3130 mm
B	Center of front axle to counterweight (Pusher)	596 mm
C	Cutting edge to center of front axle	2600 mm
D	Wheel base to center of tandem	6000 mm
E	Front tire to rear bumper	8500 mm
F	Tandem wheelbase	1535 mm
G*	Center of tandem to back of ripper	2590 mm
H*	Overall length	9568 mm
I	Track of gauge	2070 mm
J	Width of tires	2470 mm
K	Width of standard moldboard	3710 mm
L*	Width of optional moldboard	4320 mm
M*	Ripper beam width	2305 mm
N	Articulation, left or right	26°

*Optional

STANDARD EQUIPMENT

Engine And Transmission:

- Accelerator and inching pedals
- Automatic dust evacuator
- Corrosion resistor
- Dry-type air cleaner with built-in centrifugal pre-cleaner
- Engine key stop system
- Hand throttle
- HYDROSHIFT transmission
- Muffler
- Pusher type fan
- 116 kW (155 HP) / 134 kW (180HP) diesel engine
- 24 V/7.5 kW starting motor
- 24 V/35 A alternator
- 2 x 12 V/140 Ah batteries

Meter And Gauges:

- Battery discharge warning lamp
- Dust indicator
- Engine oil pressure warning lamp
- Engine-preheat indicator
- Instrument panel lamp
- Parking brake warning lamp
- Service meter

- Speedometer (km/h indication)
- Water temperature gauge

Moldboard:

- Blade manual tip control
- Hydraulic blade sideshift
- Reversible end bits and overlay end bits
- 3710 mm blade with two 6 feet cutting edges
- 90°bank cut structure

Brakes:

- Foot-operate, internal expanding type service brakes with hydraulic booster
- Hand operated, internal-expanding type parking brake

Tires:

- 14.00-24-10PR (G-2) traction-type tubed tires (front and rear)

Others:

- Adjustable console
- Adjustable seat
- Back-up alarm
- Back-up lights
- Engine side covers
- Front weight
- Guard, operator's compartment
- Head lights, front mounted
- Horn
- Mark & plate, English
- Operator guard
- Panel lamp
- Pilot check valves for blade lift, front wheel leaning, drawbar sideshift and frame articulation cylinders
- Rear tow hitch
- Rear-view mirrors
- Sandy and dusty terrain arrangement (air cleaner intake pipe extension, brushless alternator with hardened pulley, starting switch with dust cover)
- Stop and tail lamps
- Turn signal lamps (front and rear)
- Working lights

OPTIONAL EQUIPMENT

Lighting System:

- Hazard light
- Inspection light
- Licence-plate lights
- Warning beacon

Mirrors:

- Rear under-view mirror
- Rear-view mirror, cab center mount

Engine And Power Train:

- Air compressor (for tire inflation)
- Brake, oil disc, four-wheel, air actuated
- Differential, lock-unlock
- Large capacity alternator (50 A)
- Large capacity batteries (200 Ah)
- Large capacity starting motor (11 kW)
- No-spin differential
- Suction type fan
- Transmission-under guard
- Water separator

Tires:

- Traction type tubed and tubeless tires
- 14.00-24-10PR (G-2)
- 14.00-24-12PR (G-2)
- 14.00-24-14PR (G-2)
- 17.50-25-12PR (G-2)

Operator's Compartment:

- Air conditioner
- Ashtray/cigarette lighter
- Canopy (canvas top)
- Floor mat
- Heater/defroster
- Room lamp
- ROPS column
- ROPS canopy
- Seat belt (78 mm width)
- Steel cab
- Windshield wiper, rear

Work Equipment:

- Blade accumulator
- Blade cylinder guards
- Front blade
- Hydraulic blade tip control
- Push plate, front mounted
- Ripper
- Scarifier (11 teeth type)
- 12' blade with 203 mm x 16 t edge
- 13' blade
- 13' blade with 203 mm x 19 t edge
- 14' blade

Others:

- Cold area arrangement (-30°C)
- Engine oil pan and coolant heater
- Fire extinguisher
- Fuel tank, radiator and hydraulic tank cap lock
- High altitude arrangement
- Horn, additional
- Hydraulic jack
- Rain cap for exhaust pipe
- Tire inflation kit
- Vandalism protection

Attachments and Optional Equipment



Front blade:

This is an indispensable work tool for volume push - carry operations and for facilitating difficult spreading jobs involving large heaps of materials unloaded from dump trucks.

- TypeFront arc, box section type, hydraulically controlled.
- Blade length2524 mm
- Blade height850 mm
- Max. lift above ground548 mm
- Max. drop below ground157 mm



Scarifier:

This attachment digs up hard ground, like asphalt, old pavement and frozen surfaces, which are not removable by the blade. The number of teeth can be changed according to ground hardness.

- TypeV-type, 2-stage adjustable, hydraulically controlled
- Number of teeth11
- Digging width1325 mm
- Max. lift above ground320 mm
- Scarifier base970 mm
- Additional weight710 kg



Steel cab:

Additional weight.....310 kg
 Installed height.....3360 mm
 Includes from windshield washer and wiper.
ROPS: Meets ISO 3471 and SAE J1040 ROPS standards.



Ripper

KOMATSU[®]