

ROUGH TERRAIN CRANE

GR-700EXL

70 METRIC TON CAPACITY



SPECIFICATIONS

MAXIMUM CAPACITY	70,000 kg at 3.0 m
TRAVELING SPEED(MAX.)	40 km/h
GRADEABILITY (TAN θ)	57 % (at stall)
WEIGHT Gross vehicle mass	48,100 kg * 48,200 kg
-front axle	24,700 kg * 24,700 kg
-rear axle	23,400 kg * 23,500 kg * EUROSPEC
MIN.TURNING RADIUS	11.9 m (2-wheel steering) 6.7 m(4-wheel steering) (at center of extreme outer tire)
BOOM	5-section full length power telescoping boom.
Fully retracted length	11.5 m
Fully extended length	44.0 m
Extension speed	32.5 m in 145 s
Elevation speed	-2° to 80° in 77 s
JIB	2-staged swingaround boom extension. Triple offset(3.5°/25°/45°) type. Assistant cylinders for mounting and stowing. 9.9 m and 17.7 m
Length	
MAIN WINCH	Variable speed type with grooved drum driven by hydraulic axial piston motor.
Single line pull	54.9 kN {5,600 kgf}
Single line speed	143 m/min. (at the 4th layer)
Wire rope	19 mm (Diameter)
AUXILIARY WINCH	Variable speed type with grooved drum driven by hydraulic axial piston motor.
Single line pull	54.9 kN {5,600 kgf}
Single line speed	125 m/min. (at the 2nd layer)
Wire rope	19 mm (Diameter)
SWING speed	2.3 min ⁻¹ {rpm}
Tail swing radius	4,120 mm
HYDRAULIC SYSTEM	Pumps... 2 variable piston pumps for telescoping, elevating and winches. Tandem gear pump for steering, swing and optional equipment. Control valves.... Multiple valves actuated by pilot pressure with integral pressure relief valves. Circuit.... Equipped with air cooled type oil cooler. Oil pressure appears on AML display for main circuit. Hydraulic oil tank capacity.... approx. 740 liters

TADANO Automatic Moment Limiter (Model: AML-L)	Main unit in crane cab gives audible and visual warning of approach to overload. Automatically cuts out crane motions before overload. The AML monitors each outrigger extended length and automatically programs the corresponding "RATED LIFTING CAPACITY" table. With working range (load radius and/or boom angle and/or tip height and/or swing range) limit function. Automatic Speed Reduction and Soft Stop Function on boom elevation and swing. Nine functions are constantly displayed. Digital liquid crystal display: • Either boom angle or moment % • Either boom length or potential hook height • Either actual load radius or swing angle • Actual hook load • Permissible load • Either jib offset angle or number of parts line of rope • Boom position indicator • Either outrigger position or on-tire indicator Bar graphical display: • Either moment as percentage or main hydraulic pressure
OUTRIGGERS	4-hydraulically operated H-type outriggers. Each outrigger controlled simultaneously or independently from the crane cab. Equipped with extension width detector for each outrigger.
Extended width	Fully ... 7,200 mm, Middle ... 6,700 mm & 5,500 mm Minimum ... 2,800 mm, Float size (Diameter) ... 500 mm
CARRIER	Rear engine, left-hand steering, driving axle 2-way selected type (by manual switch). 4 x 2 front drive, 4 x 4 front and rear drive
ENGINE	Model..... MITSUBISHI 6D16-TLJ2A [EUROMOT Stage 2] Type 4 cycle, 6 cylinder in line, direct injection, water cooled, turbo charged with intercooler, diesel engine. Piston displacement...7,545 cm ³ Max.output...166 kW{225PS} at 2,700 min ⁻¹ {rpm} Max.torque ...705 N-m {72 kgf-m} at 1,300 min ⁻¹ {rpm}
TRANSMISSION	Electronically controlled full automatic transmission.
STEERING	Hydraulic power steering controlled by steering wheel. 4 steering modes available: 2-wheel front, 2-wheel rear 4-wheel coordinated, 4-wheel crab
SUSPENSION	Front..... Rigid mounted to the frame. Rear..... Pivot mounted with hydraulic lockout cylinders.
TIRES	29.5 - 25 - 22PR(OR), Single x 4
FUEL TANK CAPACITY	300 liters

WORKING RANGE

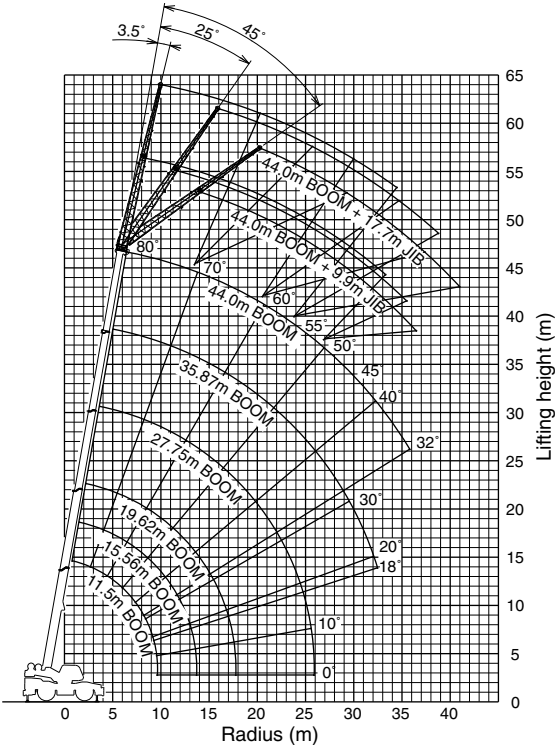

DIMENSION

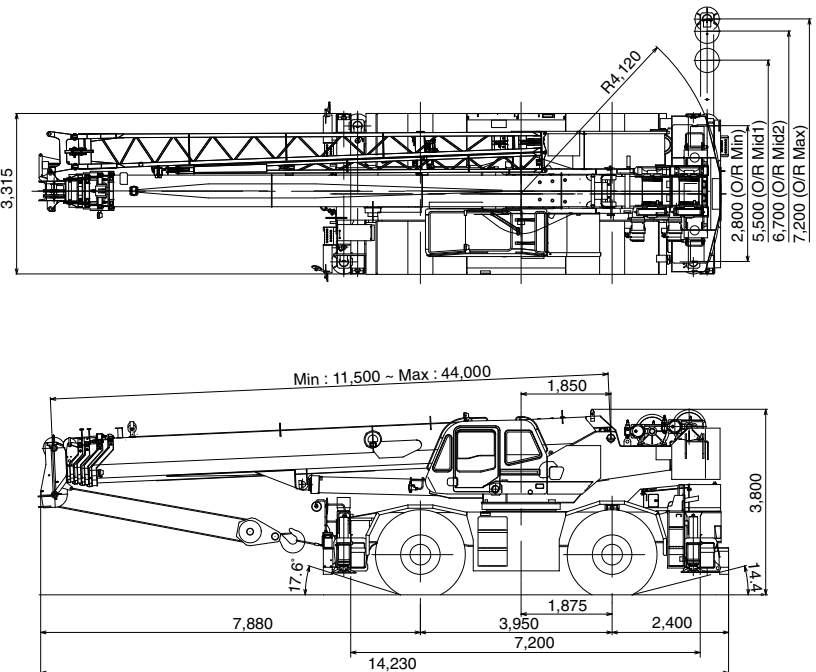

Continuing technical development requires Tadano to retain the right to make specifications, equipment and price changes without notice.

*Some specifications are subject to change



TADANO LTD. (International Division)
4-12, Kamezawa 2-chome, Sumida-ku Tokyo 130-0014, Japan
Tel: 81-3-3621-7750 Fax: 81-3-3621-7785
http://www.tadano.co.jp/indexe.htm E-mail: tdnihq@tadano.co.jp



GR-700EXL-2005-2-3000-2
Printed in Japan